

GUIDELINES FOR ECONOMICAL ASSEMBLY OF REINFORCEMENT

1 INTRODUCTION

This Technical Note recommends detailing and fixing practices which will allow some flexibility when placing steel reinforcing bars and fabric.

Steel fixing is the art of assembling reinforcement in its specified position, as shown in the drawings. Reinforcement details which artificially create fixing problems are discussed in this guideline.

Four topics are considered:

- Relieving reinforcement congestion.
- Simplification of fixing without affecting the design intent
- Reducing the number of reinforcement items to be fixed.
- Detailing to allow for variations in site measurements and to protect steel reinforcement against corrosion.

In this guideline the term *assembly of reinforcement* means *bringing together several items of steel in one or more structural members*:

- within or upon formwork close to its final position;
- using on-site cage assembly some distance from the forms, which may require craneage of the assembled steel to the forms; or
- by off-site cage assembly, which will require transportation to the site with subsequent craneage to the forms.

Each assembly method has advantages which depend on site and construction practices. A method suitable for one project may be inappropriate for another. For example, crane locations and capacity, the system of formwork adopted, the method of construction, etc may not be known to the design engineer before the contract is let, yet each can have a considerable influence on the construction timetable.

Engineering analysis of a structure generally applies to it as a whole however each member is individually designed and detailed with its own independent reinforcement. The separate members are then connected by additional reinforcement so that, after the concrete has reached full strength, the complete structure should act as previously analysed.

Throughout this guideline, we have used the term **Note** to describe a statement made about a certain topic, and the term **Hint** to indicate a recommendation or suggestion about a suitable procedure.

All the information provided in this Guideline is directed towards the construction team, that is, the design engineer, the draftsman, scheduler, steel fixer and inspector.



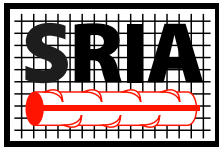

2 CONTENTS

Relieving reinforcement congestion

Recommendation 1: *To improve access for concrete and compaction without change in design.*

Recommendation 2: *For locating the column bar offset below the floor level.*

Recommendation 3: *For locating the column bar offset within the beam thickness.*

Recommendation 4: *For locating the column bar offset just above the floor level.*

Recommendation 5: *To provide a variable system for off-form assembly of column and beam cages.*

Simplification of fixing without affecting the design intent

Recommendation 6: *Allow wall reinforcement to be fixed from the most convenient side.*

Recommendation 7: *Allow for thickness of the reinforcement grid when specifying cover in walls.*

Recommendation 8: *Utilise designed reinforcement as supports.*

Recommendation 9: *Maintaining an accurate bar spacing.*

Recommendation 10: *Avoid the need for fixers to push slab bottom steel into supporting beams.*

Recommendation 11: *To improve off-form pre-assembly of beams.*

2

Reducing the number of reinforcement items to be fixed

Recommendation 12: *When detailing staggered bars, use one length where possible.*

Recommendation 13: *Carefully check variations in bar and fabric shapes.*

Recommendation 14: *Minimise the number of reinforcement cut-off points.*

Recommendation 15: *Use only one bar size in any one column lift, unless location of every bar is given in large-scale details.*

Recommendation 16: *Reduce the number of bar combinations by careful planning of construction joints and lap-splice locations.*

The Steel Reinforcement Institute of Australia is a national non-profit organisation providing information on the many uses of steel reinforcement and reinforced concrete. Since the information provided is intended for general guidance only, and in no way replaces the services of professional consultants on particular projects, no legal liability can be accepted for its use.

Detailing to allow for variations in site measurements and to protect reinforcement against corrosion

Recommendation 17: *Maintain cover and also allow for construction tolerances by careful choice of lap splices.*

Recommendation 18: *Avoid using a hook at the end of bar unless real anchorage problems exist.*

Recommendation 19: *Avoid use of hooks in small or precast members.*

Recommendation 20: *Provide a bevel at an internal corner of a wall.*

Recommendation 21: *Do not combine shear reinforcement of a beam with top reinforcement of a slab.*

Recommendation 22: *Take special precautions where a drip-groove is specified below an external member.*

Recommendation 23: *Allow for variations in length of vertical members.*

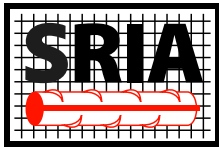

3 RELIEVING REINFORCEMENT CONGESTION

Reinforcement which is too close together will not permit concrete to be placed and compacted correctly. This is what is meant by congested reinforcement.

Steel congestion most often occurs at the intersection of one or more beams over a column. The vertical main bars of a column must be continuous through the intersection. Horizontal bars in the top and bottom of the beams must also pass through the intersection. Because the column concrete is placed before that of the beam, the position of the main column bars cannot be altered when fixing the beam reinforcement. Therefore the details must permit beam bars to be moved sideways to avoid column bars.

Additionally, column bars must be spliced at a suitable location to ensure continuity in the strength of the column. The traditional form of splice is by lapping.

Because the vertical forces in the column bars must be transmitted down the column from one bar to the next, lap splices are generally made by offset-bending one of the bars at the splice. The location of this offset within the column elevation has a great effect on construction techniques.

It can be seen therefore, that reinforcement congestion will probably occur within the column/beam intersection if the top and bottom bars of the beam and the column bar offsets are detailed to pass through that intersection.

Finally, a reinforcing bar has considerably more thickness than a line on paper. Because of the deformations on a N36 bar, it has a real diameter of 40 mm; at a scale of 1:20 it occupies nearly 2 mm of available space. If its centreline is cranked one diameter, it occupies a real space of 40 mm by 80 mm within the column intersection, or a paper space of 2 mm by 4 mm. Think about it!

3

RECOMMENDATION 1

To improve access for concrete and compaction without change in design

Situation Heavily-reinforced beam, or a narrow beam or column.

Problem Main bars are so close that concrete placement is difficult.

Solution Increase the member width; if not allowed, use two-bar bundles.

Reason Obvious.

Detailing Hint 1 With a T-beam or L-beam, top bars can be spread singly or bundled into the adjacent slab.

Detailing Hint 2 For a column, bundle the bars and use an end-bearing compression splice with a suitable sleeve.

Assembly Note Even when not detailed as suggested, seek approval to adopt this Recommendation.

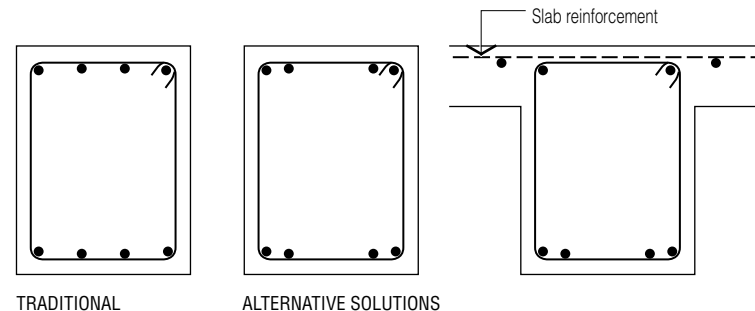

The Steel Reinforcement Institute of Australia is a national non-profit organisation providing information on the many uses of steel reinforcement and reinforced concrete. Since the information provided is intended for general guidance only, and in no way replaces the services of professional consultants on particular projects, no legal liability can be accepted for its use.



RECOMMENDATION 2

For locating the column bar offset below the floor level

Situation Where the beam and column are of similar width.

Problem The bending dimension (the offset or crank) depends on the member sizes, bar diameters, cover, etc. Then the exact position of the crank must be determined when fixing the column cage from the floor below; there is little margin for error. If four beams intersect over a column, the offset location must avoid even more layers of steel.

Solution Locate the bends below the lowest soffit of all beams.

Reason Through the intersection there will be only vertical column bars rather than a sloping portion.

Design Hint Check the column strength at beam soffit. Allow for extra ties at the offset bend to resist outward forces. Define the relative position in plan-view of each column-bar at the lap. Spread beam top-bars into the slab to create space.

Detailing Hint Show extra ties with different dimensions at the top bend and within the lap to maintain the location of the splice portion during concreting.

Scheduling Hint Keep upper bend about 50 mm below beam soffit as a tolerance. Do not assume the offset will be just one column-bar diameter.

Assembly Note In practice, pre-assembly of the column cage away from its final location requires knowledge of the beam-bar locations. Considerable accuracy is essential to ensure that the lap will be correctly oriented.

Inspection Note Before concreting, check the position and spacing of the cranks and laps at the floor level above.

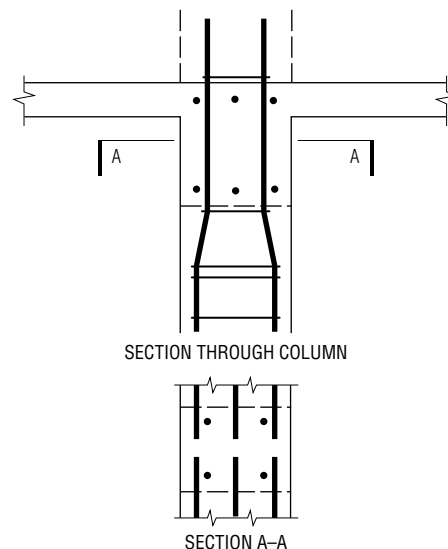

RECOMMENDATION 3

For locating the column bar offset within the beam thickness

Situation Where the beam is considerably wider than the column, for example, using bandbeams with or without prestressing.

Problem The situation here is much less critical than in Recommendation 1 because the horizontal position of the beam steel can be varied on site to adjust to the space available.

Solution Locate the upper bend of the crank about 50 mm below the beam top-bars. If the beam depth is adequate, locate the bottom bend above the beam bottom-bars.

Reason Because of the greater beam width, the space occupied will be less restrictive on steel placement and concreting.

Design Hint The concrete of the beam will provide resistance to the horizontal forces generated at the bends. Beam top bars can be spread into an adjoining slab. A fabric cage from floor to beam soffit permits easier pre-assembly of the column steel.

Detailing Hint For the crank to fit into the beam depth as described above, the

depth needs to be at least 450 mm (see **Scheduling Hint**). Using a "General Note", indicate that the beam steel may be moved sideways to bypass column bars as necessary.

Scheduling Hint The slope of the crank must be no more than 1:6 on the bar centreline. Using a "two-diameter plus 10 mm" overall offset with a crank length of 10 diameters will satisfy this requirement. A minimum of 300 mm is normal up to N28, with 400 mm for N32 and N36.

Assembly Note Care is still needed to position the crank so that the lap at the next floor will be alongside the next column bar. Pre-assembly of the complete column cage on the ground or off-site can be considered as an option.

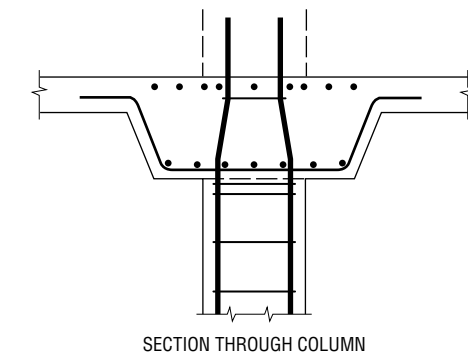



RECOMMENDATION 4

For locating the column bar offset just above the floor level

Situation Generally without restriction at intersection of one or two beams over a column. Should be mandatory where architectural limitations unrealistically impose narrow member sizes on the structural designer.

Problem To avoid many of the restrictions imposed upon Recommendation 1. This method is also essential if Recommendation 5 is adopted.

Solution Firstly, lap the bar just above floor level with the crank starting above the splice. Secondly, continue the column bars without bending through the intersection level of the floor above

Reason Through the intersection, each column bar now occupies only a space equal to its diameter. Locating the cage will be much simpler. The lap splice orientation and the length can be inspected and checked before concreting.

Design Hint 1 Extra ties will be needed at the bend of the crank. Consider use of fabric cage from floor to soffit, or even through intersection.

Design Hint 2 If the column size above the floor differs from that below, terminate the lower bars below floor level as necessary. Provide a separate set of straight lap-splice bars and ties to match the new cage size.

Detailing Hint All column ties can have the same dimensions. Show orientation of main bars with lap-splice in a cross-section

Scheduling Hint Wherever possible provide identical bars to permit interchangeability with many columns.

Assembly Note The orientation of the next storey column bars in relation to the concreted lower bars can be decided during fixing. This permits greater freedom of choice of fixing method. Also permits pre-assembly outside formwork. Cage can be stood up on four bars fixed firmly in corners, with remainder left partially loose until cage located accurately.

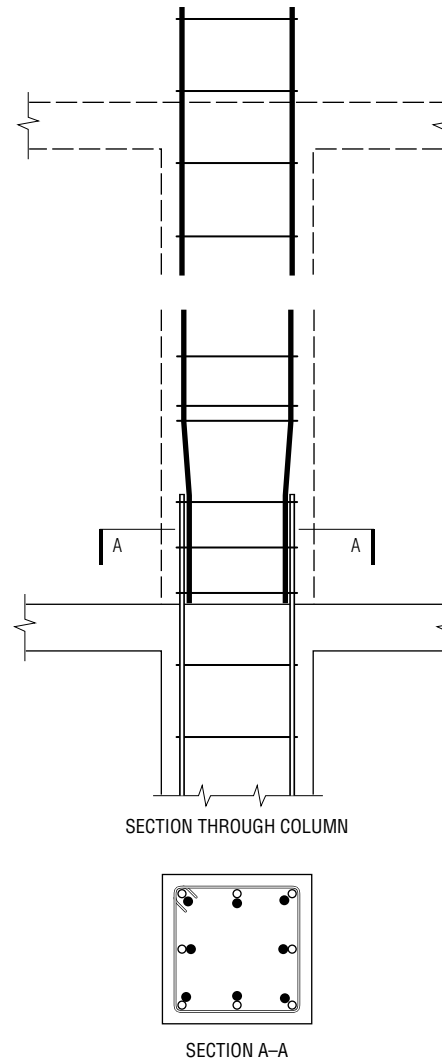

RECOMMENDATION 5

To provide a variable system for off-form assembly of column and beam cages

Situation 1 In most cases where one or more beams intersect over a column. It is particularly suitable for spandrels (see also Recommendation 21).

Situation 2 Where off-form or off-site pre-assembly of the beam cages is adopted.

Problem To overcome beam/column steel interference and simplify fixing of beam steel.

Solution Arrange the column cages as given in Recommendation 4. Pre-assemble the beam steel cages comprising all bottom steel and two nominal-size tie bars in the top corners of the closed stirrups. The cage must fit easily into the clear span between columns. After placing the cage, positive moment anchorage, consisting of short bars, are dropped through the beam cage and column bars. Negative moment beam top-steel is similarly fixed separately.

Reason Placing bottom continuity bars and top negative moment bars after the cage is placed means there is no manhandling of a cage over and through the column splice bars. The advantages are even greater when four beams intersect.

Design Hint 1 The continuity bars in the bottom would generally be fewer and of smaller sizes than the main bottom bars. The length each side of the column may be either tension or compression splice, care being taken to check for stress reversal.

Design Hint 2 Take advantage of the shear strength clauses of AS 3600 which allow simpler detailing if tensile reinforcement is not terminated within a tensile zone. Use of fabric as shear reinforcement can also reduce number of alternative fitment spacings with faster assembly.

Detailing Hint 1 For formwork economy, beam sizes should be identical where possible. If beam spans are nearly identical, and loading conditions are uniform, allow for construction flexibility with identical beam cages. Make all bottom bars same length, just shorter than the clear span; this assists sorting out and reduces shear steel detailing.

Inspection Note Check the basic cages before lifting into forms. Then check additional bottom and top bars after placement.

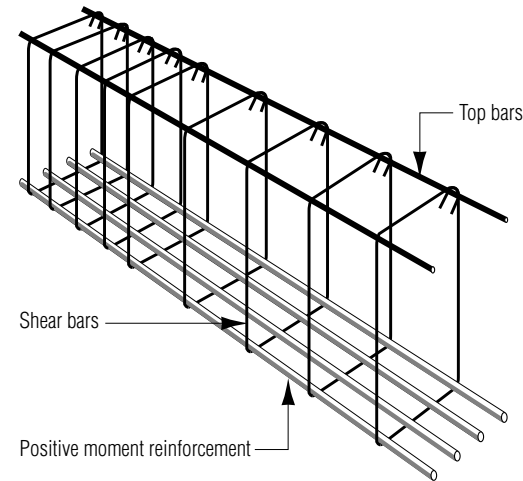

BASIC CAGE ARRANGEMENT

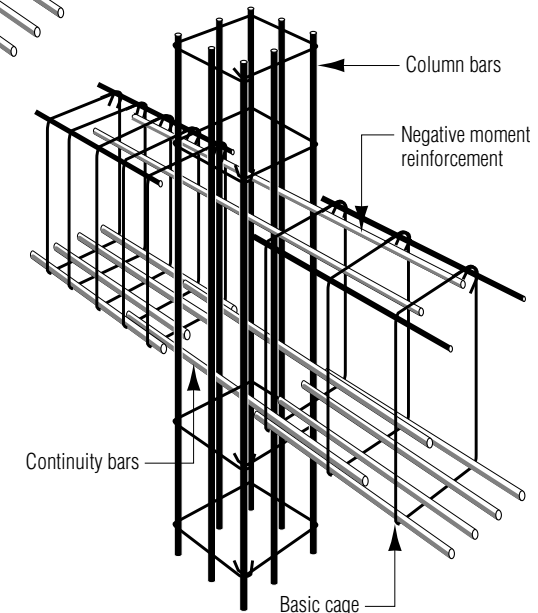

AFTER ASSEMBLY AT INTERSECTING COLUMN

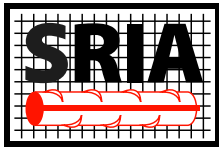

4 SIMPLIFICATION OF FIXING WITHOUT AFFECTING THE DESIGN INTENT

Detailing of reinforced concrete is a necessary, and sometimes expensive, operation. In principle the details are expected to provide both design intent and construction requirements. However, as regards the latter; there are many situations where many details would be necessary if every minor variation was to be shown.

For this reason most design offices adopt "Standard Details" to express the design intent because individual member requirements can then be given in tables. From these "Standard Details" all the variations necessary for construction must be provided by detailer or scheduler.

Individual member details which need special treatment can be given as an "exception" rather than as the general rule

This part of the Guideline illustrates some cases where variations to standard details can be made at the site level, sometimes without direct reference to the designer.

RECOMMENDATION 6

Allow wall reinforcement to be fixed from the most convenient side

Definition In this Recommendation, the term *grid* is used to describe two layers of steel fixed together at right angles. Thus, one grid of wall steel consists of one horizontal layer tied to one vertical layer; a wall can have two grids, each consisting of one layer horizontally and one vertically, ie four layers in total.

Problem Supporting the horizontal bars.

Situation 1 For each grid.

Solution The vertical bars are erected first, supported by previously-cast concrete and tied to existing starter bars. Then the horizontals are lifted up on the near side and tied. If a wall has two grids, this method applies to both; the horizontals should be on both near sides. Fabric can provide a complete grid in one piece.

Reason Hopefully this is obvious.

Caution Never deliberately give a detail which unnecessarily requires fixers to manually fix horizontals behind verticals, either by threading them through or by lifting them up, over and down. This practice is unsafe and time-consuming.

Situation 2 A boundary wall, or core wall, where all construction is done from one side of the wall and there is no access from the "far face"

Solution Unless instructed otherwise, allow fixing from the appropriate side for either grid.

Design Hint If the design is such that horizontal bars must be located on the other side of the verticals, then this must be made particularly clear in the drawings.

Detailing Hint With "standard details", ensure they provide an adequate solution. To restrain the verticals, make the spacing of bars the same below and above a construction joint. For example, N12-200 below and N12-200 above, not N12-350 above.

Assembly Note If horizontal bars must be fixed on the far side, first place two or more verticals temporarily near the far face, loosely support the horizontals on them, place the remainder of the verticals, properly fix the horizontals, then recover the temporary verticals and fix them. Messy, but one way out.

Scheduling Hint If the height of the wall is variable, check whether tops of bars can be trimmed on site, or if variable-length bars can be used; eg five or ten bars in groups with the same dimensions.

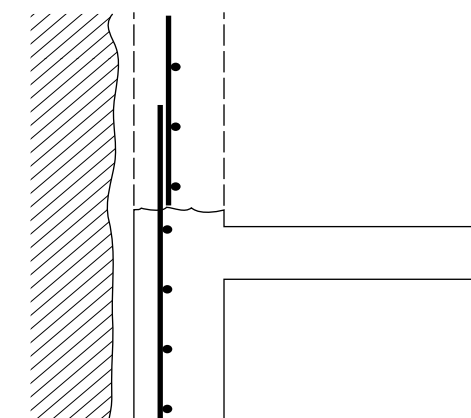
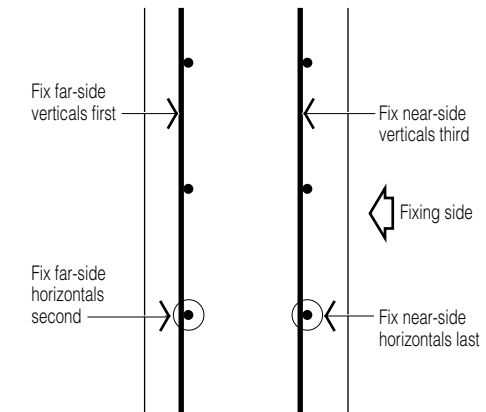

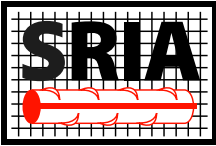

RECOMMENDATION 7

Allow for thickness of the reinforcement grid when specifying cover in walls

Situation 1 Thin wall with one grid of steel.

Problem To which face should cover be specified? There can be conflicting requirements – minimum cover compared with adequate compaction. It is the horizontal bars which interfere with concrete placement.

Solution Cover probably should be specified to the vertical bar.

Reason The position of the vertical bars should be defined first (see Recommendation 6).

Design Hint Specify the cover to the layer of reinforcement nearest the external surface with the worst exposure condition. Cover to horizontal bars is generally not critical for strength. Shrinkage reinforcement horizontally may exceed that vertically.

Detailing Hint The real size of a deformed bar is about 10% to 12% more than the nominal size. Check that external cover plus two layers of steel plus internal cover does not exceed wall thickness. Always allow a realistic tolerance for one face; in fact avoid specifying cover on both sides.

Assembly Note It may be possible to tie and weld each grid of bars on the ground and lift them into place. If the vertical bar spacing differs each side of a construction joint, tie verticals to two temporary horizontal bars at new spacing.

Situation 2 Wall with two layers of reinforcement

Problem Thin wall with two layers.

Solution AS 3600 requires two grids only when the wall is more than 200 mm thick. Are two layers really necessary for strength? If the answer is "yes", the above Recommendations for Situation 1 apply also; if "no" use one layer and obtain better concrete placement.

Design Hint Check that the reinforcement location will provide the necessary strength, allowing for room to place concrete between the grids. Two grids of fabric are easier to place than four layers of bars.

Detailing Hint Each grid should be the same – fix verticals before horizontals.

Assembly Note Ensure an adequate number of bar spacers are used to maintain both cover and spacing between the layers.

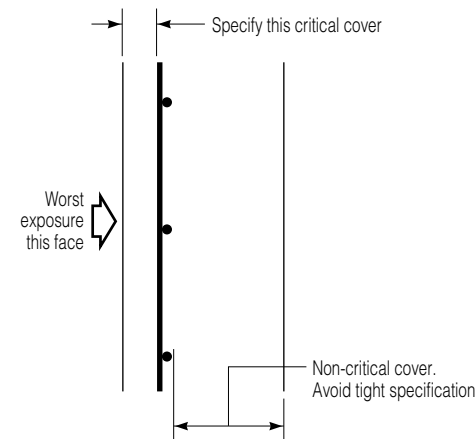

RECOMMENDATION 8

Utilise designed reinforcement as supports

Situation 1 Pad footing with bars in two directions.

Problem How to avoid using bar chairs under every bar in the pad footing.

Solution Relocate two or more footing bars from the original top layer on chairs as support for all bars of original bottom layer. These in turn support remainder of original top layer.

Reason Easier to fix bars on soft ground. Big reduction in amount of tying.

Design Hint Allow for this method when calculating bottom cover. Effective depth will be similar for each layer. Fabric in one or two grids, interleaved, may be suitable. If bottom cover is maintained, and the concrete depth over the upper steel layer is not reduced, this method requires no changes to the original design.

Detailing Hint Show the "standard detail" this way.

Scheduling Hint Allow for thickness of three layers when determining starter-bar lengths.

Assembly Note Permits pre-assembly of the pad footing and chairs, with column

starter-bar cage tied loosely in position, all ready to be craned into position.

Situation 2 Supporting column starter bars on the pad reinforcement.

Problem To allow for variations in level of the excavation, in thickness of the footing and of location of the starters after concreting.

Solution Consult with site about final footing levels to ensure adequate lap length with column is scheduled. Then use L-shaped starter bars, without offset-bends. See Recommendation 4.

Reason The depth of the concrete should not be controlled by the position of the bends.

Design Hint No special requirements. Check lap-length for tension and compression.

Detailing Hint Detail at least three ties as support for starter-bars. Avoid varying column size below ground floor level.

Scheduling Hint Bottom leg of starter must rest on at least two pad bars; a standard 90° cog may not be long enough. Even if not shown, supply extra

ties for assembly purposes; they will be of same dimensions as column ties. Column bars will have crank located at bottom. See Recommendation 4 also.

Assembly Note L-shaped starters permit more accurate positioning; any error here affects whole structure. Cages can be assembled before excavation is completed.

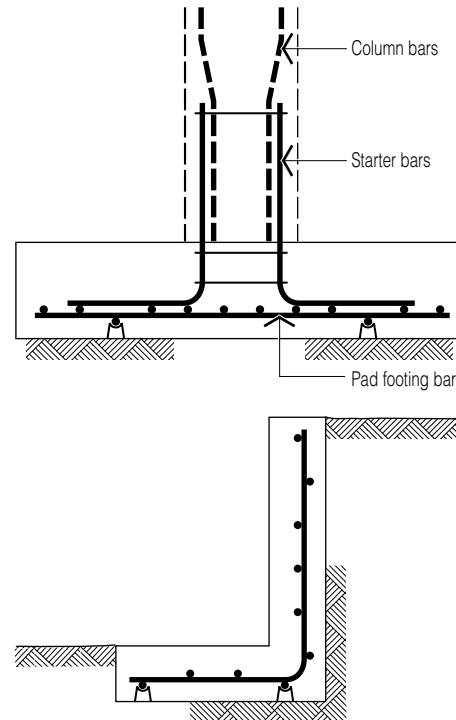

Situation 3 Small retaining wall where footing and wall bars are combined.

Problem Support of many L-shaped bars on earth foundation.

Solution Similar to pad footing; use two or three longitudinal bars as chaired supports for the wall bars.

Design Hint The vertical wall bars must support the horizontal wall bars. See Recommendation 6. Also see Recommendation 8, Situation 1 for design hint on cover calculations.

Detailing Hint All longitudinal footing bars may be used to support the L-shaped wall bars, but generally two or three are advisable. Also, one or two horizontal wall bars could be detailed behind the vertical wall bars for erection purposes.

Scheduling Hint If the height of the wall is variable, check whether tops of bars can be trimmed on site, or if variable-length bars can be used; eg five or ten bars in groups with the same dimensions.

Assembly Note Use one or two horizontal bars in the wall as temporary fixing bars, whether detailed that way or not. Retrieve and locate at front if not approved.



RECOMMENDATION 9

Maintaining an accurate bar spacing

Situation 1 In walls and slabs, particularly flat slabs and flat plates.

Problem Maintaining the correct design area of steel across the placing width.

Definition AS 3600 uses the terms "design strip", "middle strip" and "column strip". The latter two are the "placing strips" used in this Recommendation.

Solution Specify always the size of the bars, the number to be placed in each zone and the spacing as a guide to fixers and inspectors.

Reason When a detail says "N16 at 150", it means that average spacing of 150 mm is required. What is more important is that the total number of bars is specified, not just the spacing.

Design Hint For each design strip, calculate total steel area (mm²) instead of spacing.

Detailing Hint Convert this bar area into a whole number of bars, and distribute the appropriate number across each placing strip. Provide the average spacing for fixing guidance.

Example The design strip steel area is 10 500 mm² in a strip 7800 mm wide. For N16 bars of area 200 mm², calculate 52.5 bars. Specify the next whole number "53-N16". Assuming the column placing strip is one half the design strip width but is allocated 60% of the moment, then specify "33-N16" at an approximate spacing of "120 mm". Each half middle strip then contains "10-N16 at 200".

Scheduling Hint Order the number of bars if specified; otherwise calculate the number from "width of slab or strip including edge cover" divided by "specified spacing". Round-up as shown above.

Assembly Note The outermost reinforcement parallel to an exposed edge should be located one-half of the specified spacing (but not less than the cover) from the edge. If the details specify the edge spacing, the internal bars may need to be spread out marginally.

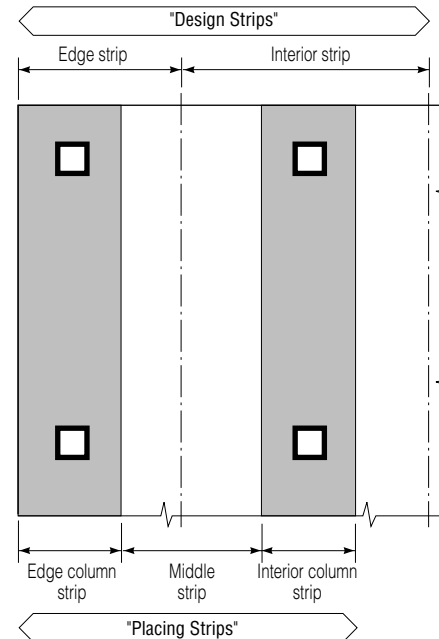

Situation 2 At corners of walls or for vertical bars in walls.

Problem Change of bar spacing for minor design advantage.

Solution Ensure that bar spacing is uniform, making it much simpler to tie the next set of bars.

Reason Minor changes can have a snowballing effect on future construction.

Inspection Note A uniform spacing makes inspection easier.



RECOMMENDATION 10

Avoid the need for fixers to push slab bottom steel into supporting beams

Situation A continuous slab with top steel over supporting beams.

Problem If the beam cage is in position first, it can interfere with placing the slab steel.

Solution Specify staggered slab bar ends to avoid penetration at both ends, even if only one bar length is required (see Recommendation 12).

Reason Obvious.

Design Hint The degree of penetration is a design decision.

Detailing Hint Specify the penetration distance in millimetres. If total penetration is required, cut off bottom steel clear of beam cage and push short bars through the beam to give a lap-splice each side.

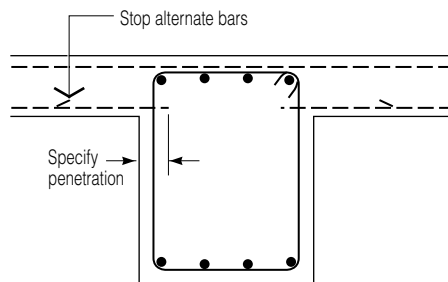

RECOMMENDATION 11

To improve off-form pre-assembly of beams

Situation A rectangular column layout and uniform loading.

Solution Detail identical reinforcement in as many beams as possible.

Reason Not only will pre-assembly be advantageous, but reinforcement cages already on site can be substituted without delay in another area if changes to the construction program occur.

Design Hint 1 With uniform loading, shear steel (stirrups) at identical spacings can be repeated in many beams. Fabric stirrups can be adopted for extra cage rigidity. AS 3600 permits simplified design for shear strength if main tensile bars are not terminated within a tensile zone.

Design Hint 2 "Custom design" of every beam has a considerable cost. The method of specifying a limited number of identical beams is the basis of structural steel frame design, even if the steel sections are over designed. The ability to make minor adjustments in reinforced concrete design should not be taken to extreme limits.

Detailing Hint Use an identical number, size and length of bottom main bars for as many beams as possible. Make up any extra steel with loose bars. Follow Recommendation 5. Make use of "standard details" with tabulated instructions.

Scheduling Hint Because the cages should be identical, check with site for clear-span dimensions.

Assembly Note Permits prefabrication, faster fixing and is in line with previous Recommendations.

Inspection Note Cages can be inspected in detail before placing in forms, then only the extra loose bars need be checked before concreting.

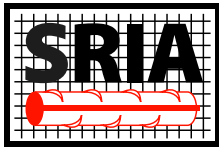

5 REDUCING THE NUMBER OF REINFORCEMENT ITEMS TO BE FIXED

Each bar that is shown on a drawing requires many other people to take appropriate action, which implies that time is spent. Some of those involved are the designer and checking engineer, the draftsman and scheduler, quantity surveyor and estimator, steel fixers and inspectors.

This section offers suggestions for reducing the total number of reinforcement items; to do this does not necessarily mean a reduction in the total quantity of steel, but they should be considered in the context of reducing the overall cost and time.

RECOMMENDATION 12

When detailing staggered bars, use one length where possible

Situation Bottom steel in slabs generally. The same approach applies to top steel as well.

Problem To provide the most economical quantity of steel, without increasing the amount of sorting and fetching on site.

Solution Is best explained with sketches. **Layout 1** indicates the strength requirements - all bottom bars are the same size and length. Because design codes usually allow 50% of the bars to be "cut-off" short of the support or column line, **Layouts 2 or 3** are possible solutions. **Layout 3** is strongly recommended.

Reason AS 3600 requires that in flat slabs, 50% of bottom bars must be lapped 50-bar diameters near the column centre line. The remainder are to be terminated no more than 1/10 th clear span from the face of the nearest support. This applies to middle and column placing strips. **Layout 3** therefore provides much greater tolerance for placing.

Design Hint 1 With bars as bottom reinforcement, it is simpler if the same bar size is used throughout the whole slab and the spacing is varied within each strip. With narrow fabric strips, the

wire size can be changed or the spacing between each strip can be modified.

Design Hint 2 For flat slabs AS 3600 permits a more uniform bottom steel layout. Steel additional to a uniformly-spaced layer can always be provided by a couple of extra bars. Wherever possible use a "standard detail" with a schedule showing panel details.

Detailing Hint 1 The requirements for an end span are slightly different. 100% of bottom bars must go into the support. Odd shaped panels need special attention.

Detailing Hint 2 To avoid complications, decide which layer of the bottom bars will be placed first (north-south or east-west) and stick to it.

Scheduling Hint If there are an odd number of staggered bars in an end span, the extra bar should be a long bar. Use as few different lengths as possible. Group identical bars together in a bundle and label it to identify the several panels where the steel will fit.

Assembly Note If detailing is simplified then a bar taken from one bundle may often suit several locations. If every bar

must be tailor-made for each position, never open a bundle labelled for another area.

Inspection Note One bar length, when staggered, permits easier visual checking. In particular check that end cover to an edge is clear of all steel.

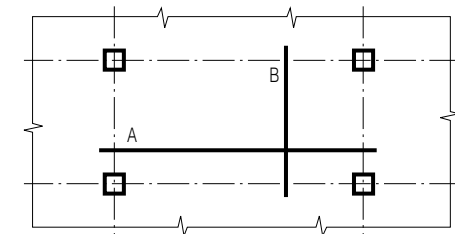

LAYOUT 1

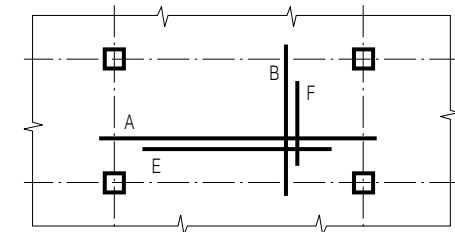

LAYOUT 2

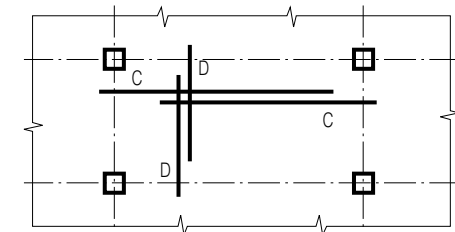

LAYOUT 3



RECOMMENDATION 13

Carefully check variations in bar and fabric shapes

Problem Changes of concrete outlines can unwittingly create multiple bar shapes.

Solution If a "typical detail", such as a cross-section of an edge is referred to several times, ensure that the detail really applies in all cases and matches the architectural shape.

Reason Obvious.

Detailing Hint Every shape, actually drawn or implied, requires additional action by others, but do not leave too much to other's imagination.

Scheduling Hint Each shape requires a different set-up of bending dimensions, with a consequent chance of error.

Inspection Note Both architectural and engineering drawings must be referred to.

RECOMMENDATION 14

Minimise the number of reinforcement cut-off points

Situation Particularly bottom and top steel in slabs.

Problem Follows on from Recommendation 12.

Solution One bar length staggered when placed, will provide two cut-off locations; this is quite adequate.

Reason Minor savings in steel length will not compensate for subsequent site delays.

RECOMMENDATION 15

Use only one bar size in any one column lift, unless location of every bar is given in large-scale details

Situation Applies to all columns, except in very tall buildings where bundled bars are used.

Problem Guaranteeing the desired result.

Solution Specify one bar size in any one column lift.

Reason Ensuring the right bar goes where it is designed.

Design Hint 1 The most economical column is one with the same dimensions for many storeys, adequate room for vibrators and any embedded duct-work, the minimum percentage of high strength steel, and high strength concrete which can vary up the building.

Design Hint 2 Where possible, specify the same concrete strength for all columns throughout one storey.

Detailing Hint Ensure each location is clear. Consider giving instructions for a template in complex cases. With bundled bars, specify the location of each end-bearing splice.

Inspection Note With circular columns in particular, check orientation of every main bar relative to the structure.

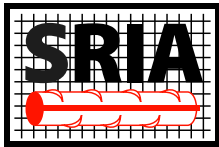

RECOMMENDATION 16

Reduce the number of bar combinations by careful planning of construction joints and lap-splice locations

Situation Retaining wall with various levels. As an example, this wall has 14 sets of bars. Each set consists of an L-shaped bar coming out of the footing, and lapping with a straight bar in the wall.

Problem If all bars were made in one piece, there would be seven different shapes; five to fit into the sloped top, and two sets to match the change in footing height.

Solution 1 Provide identical footing bars. Then supply the wall bars in two lengths so that they are supported by the top of the footing. Trim the top ends to suit any slope (oxy torch or other device); this is the disadvantage of this method. This solution is best for heavy bars or fabric sheets.

Solution 2 Provide two sizes of footing bars, and one length of wall bar. The latter can be adjusted for position by varying the lap length from the minimum at the right hand side. That the wall bar is not supported by concrete is a disadvantage, but two or three horizontals can be used as preliminary supports. This method is suited to smaller-size bars.

Caution Solution 2 may not work if the wall slopes more than can be accommodated by the lap length. An additional bar length may be needed for the sloped top.

Design Hint Nothing special, but the solutions provide for flexible site dimensions. It is essential that the spacing of the wall bars is the same as the starter bars.

Detailing Hint To get a rush job started, keep the footing bars as few and as simple as possible.

Scheduling Hint Provide adequate lap length with the L-shaped footing bars; the wall bars can be amended for wall height after actual levels are known.

Assembly Note The preferred method for fixing should be advised to the scheduler.

Inspection Note On a long sloping wall, groups of bars of the same length are usually provided, each group differing by 100 mm or so to reduce handling and sorting and relieve pressure on tolerances. Take site adjustments into account and do not expect high accuracy at BOTH ends of the wall bars.

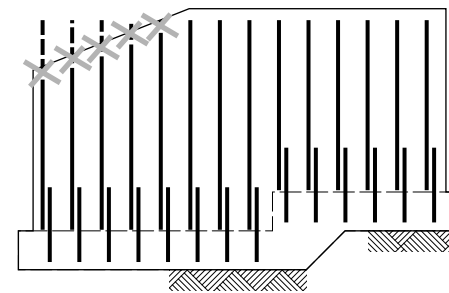

SOLUTION 1

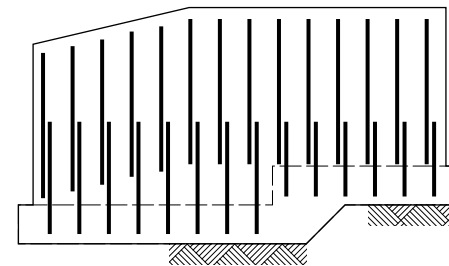

SOLUTION 2

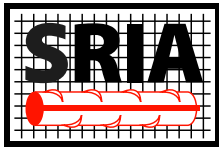

6 DETAILING TO ALLOW FOR VARIATIONS IN SITE MEASUREMENTS AND TO PROTECT REINFORCEMENT AGAINST CORROSION

Corrosion of reinforcement inside commercial or residential buildings is rare.

Reinforcement is very much more at risk when exposed to polluted air, to sea water or sea spray, to aggressive industrial environments, and to other atmospheric or ground-water conditions.

The cheapest and most effective protective device is concrete of the correct quality, properly placed and compacted, with adequate real cover to the steel.

In addition, if reinforcement is not fixed in its designed position then the strength of the structure can be reduced.

This section illustrates how concrete cover can be controlled in various situations.

RECOMMENDATION 17

Maintain cover and also allow for construction tolerances by careful choice of lap splices

Situation Wall of a tank with reinforcement continuous around the corner. Only one grid of steel is shown – the problem gets worse with two grids.

Problem If the bar is to be installed in one length, it must have a bend at each end (LL-shape) and be fixed to match other reinforcement and for work, possibly in place already.

Solution 1 Use two L-shaped bars per side of wall, lapped well outside the corners.

Solution 2 Use an L-shaped bar around each corner, lapped with a straight bar well away from the corner.

Reason Flexibility to allow different arrangements of wall forms and to keep laps out of corners.

Design Hint Ensure vertical spacing between horizontal bars in walls and corners are the same to give something to tie to.

Detailing Hint The specified lap length must be more than the minimum to allow for construction variations. See also Recommendation 7. Check bend at corner will fit into available concrete space. If possible specify a large fillet in the corner.

Scheduling Hint Corner bars should be identical. Adjust straight bar lengths to allow for the various wall lengths.

Assembly Note A grid consisting of the straight horizontals and verticals (not drawn here) can be erected full height before the corner is assembled. Fabric provides a suitable substitute.

Inspection Note Check that corner bar has adequate cover to the inside corner.

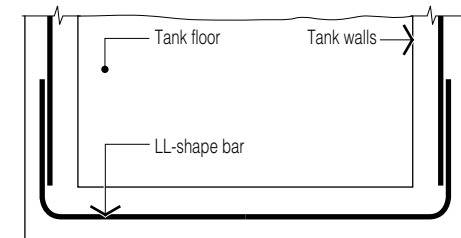

ORIGINAL PLAN-VIEW OF TANK

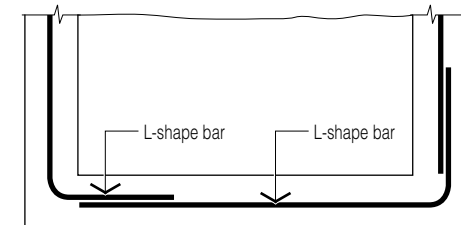

SOLUTION 1

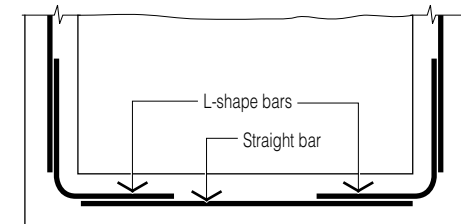

SOLUTION 2

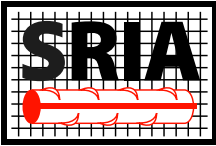

RECOMMENDATION 18

Avoid using a hook at the end of bar unless real anchorage problems exist

Situation At the end of a bar at the outer edge of a cantilever.

Problem Concrete thickness is inadequate after allowing for cover from both surfaces of the concrete added to the overall dimension of the hook.

Solution 1 Rethink the design – is the use of the hook just habit? If yes, delete the hooks.

Solution 2 Rethink the design – can the anchorage stresses really be calculated? If yes, use smaller-diameter bars with shorter development length.

Detailing Hint Bring likely problem areas to designer's attention.

Scheduling Hint Contact the contractor if problem foreseen.

Assembly Note 1 If the bars are hooked, and there are no other bends, rotate hook until horizontal and fix to additional tie bar. A hook should work regardless of its orientation.

Assembly Note 2 Never cut the hook off; tell the supervisor or inspector of the problem.

Inspection Note Members such as this are extremely prone to corrosion, particularly with thin balconies of home units. Insist on proper supports for steel and ensure bar ends are kept clear of extreme edge.

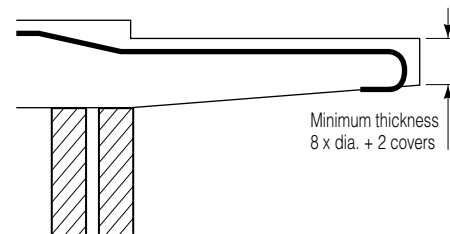

RECOMMENDATION 19

Avoid use of hooks in small or precast members

Situation Where anchorage is essential.

Problem A hook or cog has a real size much bigger than a pen line appears on paper.

Solution Draw samples to a realistic scale and advise of problems to designer.

Reason A standard 180-degree hook measures at least 8 bar diameters overall, and a 90-degree cog is about 16 bar diameters in depth.

Design Hint Review stress in vicinity of bar end. It may be so large that a welded cross piece must be used (as with bars under the load on a corbel).

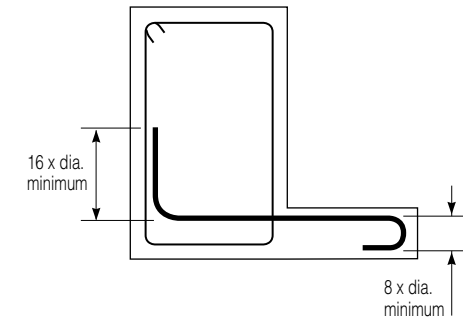

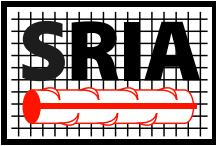

RECOMMENDATION 20

Provide a bevel at an internal corner of a wall

Situation Where a bent bar must fit around a corner. See examples in Recommendation 17.

Problem Insufficient cover at inside of bend.

Solution Provide an adequate bevel inside the corner or specify greater cover to bar in the wall.

Detailing Hint Remember that the minimum bend diameter of a bar is 5 bar diameters.

Scheduling Hint Do not reduce pin size below recommended minimums.

Assembly Note Avoid cutting the inside corner.

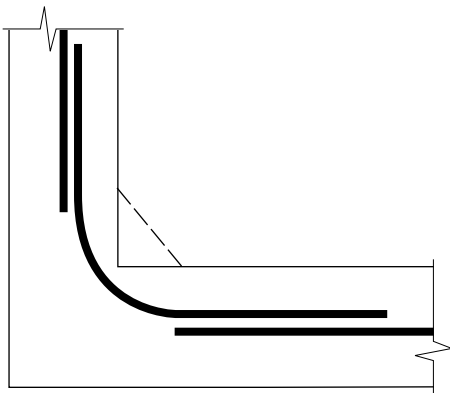

RECOMMENDATION 21

Do not combine shear reinforcement of a beam with top reinforcement of a slab

Situation At a spandrel beam.

Problem The projecting slab bars prevent fixers handling the cage, thus making placing the beam extremely difficult.

Solution Design and detail the two sets of steel independently.

Reason Shear reinforcement of a spandrel is often used for torsion resistance as well, and should be closed ties with 135-degree hooks. The spacing is unlikely to correspond to that required for flexure by the slab steel.

Design Hint The bar size of the ties and the slab steel will probably differ. Allow for this in cover calculations.

Detailing Hint Draw the beam as a cage as shown in Recommendation 5. Specify the slab top steel separately. Specify adequate support for cage and bars to prevent rotation within the forms.

Scheduling Hint Check required height of chairs for top steel support and particularly for support of construction traffic in this edge situation

Assembly Note 1 The beam cage can be prefabricated as previously described; it should be placed first. Then fix slab bottom steel, sliding it through cage to get adequate penetration. Do not let it touch outer edge. Finally fix slab top bars with hook, if detailed, inside the beam cage and not at outer edge.

Assembly Note 2 The aim is to avoid twisting the beam cage within the form or to stop the top bar hook from reducing side cover.

Inspection Note Carefully check for reduced cover at beam outer face, especially if an exposed spandrel.

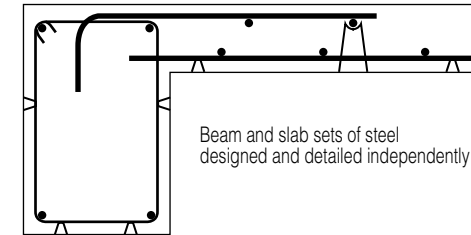

CORRECT DETAIL TO PREVENT THE FOLLOWING

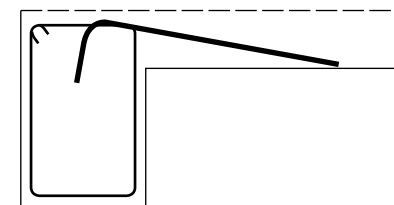
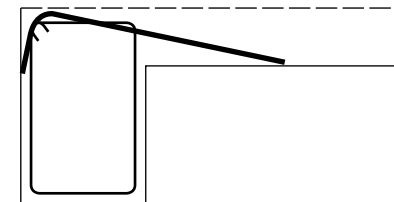
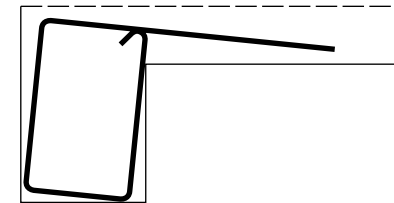

RECOMMENDATION 22

Take special precautions where a drip-groove is specified below an external member

Situation External beams and precast wall panels, and at edges of balconies.

Problem Corrosion of steel because of water penetration and reduced cover.

Solution Specify extra cover at soffit of beam to allow for depth of drip-groove, and allow for possible reduction in effective depth of beam bottom steel. Alternatively, introduce a "drip-bulge" rather than a "drip-groove", although this may increase formwork costs.

Scheduling Hint Allow for reduced size of cage fitments.

Assembly Note If a drip-groove is used, increase height of bar supports in bottom of beam.

Inspection Note These grooves are very likely to cause cracks and steel corrosion will follow.

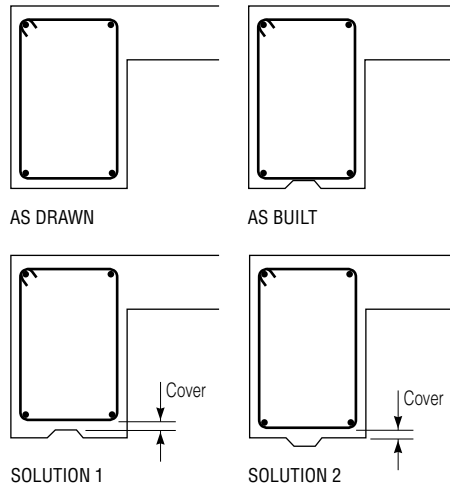

RECOMMENDATION 23

Allow for variations in length of vertical members

Situation 1 Supporting steel cages for cast-in-situ bored piers.

Problem To restrain cage shape and position in bore hole.

Solution Step 1 Pre-assemble cages using wire helix (spiral) or fabric cage. Weld short bars in cross-form to main bars; more than two may be needed for long cage.

Step 2 Support cage across hole with removable timber or steel piece.

Scheduling Hint Check whether or not cage must be full depth of hole. Provide range of lengths so that cage can be prefabricated early, and placed and concreted immediately excavation is approved.

Situation 2 At roof level where column bars are to be bent into slab.

Problem To ensure adequate cover is maintained.

Solution Use separate L-shaped bars lapped to column bars.

Design Hint Keep the number of bent bars to a minimum to reduce steel congestion. It may be possible to locate top of L-bar at mid-depth of slab.

