



The Steel Reinforcement Institute of Australia is a national non-profit organisation providing information on the many uses of steel reinforcement and reinforced concrete. Since the information provided is intended for general guidance only, and in no way replaces the services of professional consultants on particular projects no legal liability can be accepted for its use.

FITMENTS

Fitments are defined in Clause 1.6.3.42 of AS 3600 (2018)¹ as a “Unit of reinforcement commonly used to restrain from buckling the longitudinal reinforcing bars in beams, columns and piles; carry shear, torsion and diagonal tension; act as hangers for longitudinal reinforcement; or provide confinement to the core concrete.” A typical fitment is shown in **Figure 1**. While AS 3600 has always adopted the terminology ‘fitment’, they are commonly referred to as either ties, stirrups, ligatures or helix. Note that the term ‘tie’ was redefined in AS 3600 (2009)² as a “tension member in a strut-and-tie model”, and the term helix refers to helical reinforcement, which was introduced in AS 3600 (2009), with the same definition now included in Clause 1.6.3.50 of AS 3600 (2018), “reinforcement that is wound in a helical fashion around the main longitudinal reinforcing bars in a column or pile restraining them from buckling and to carry shear, torsion and diagonal tension or around tendons at an anchorage to resist bursting action effects.”

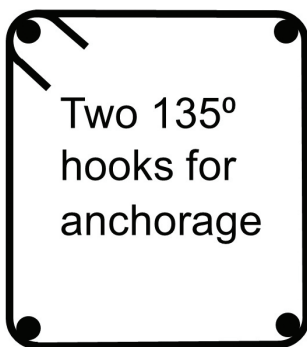

Figure 1
Typical closed fitment

Typically, fitments will be closed fitments as defined in Clause 1.6.3.12 of AS 3600 (2018), “A unit or multiple units of reinforcement used as an external or internal fitment that form a continuous perimeter around a concrete element with the ends of the fitment anchored into the concrete using a minimum of 135° hooks around a longitudinal bar.” While a closed fitment would typically resemble the single unit or shape shown in **Figure 1**, the reference to multiple units is to allow for the various options covered in Clause 8.3.2.4 of AS 3600 for the anchorage of shear reinforcement. These include anchorage by a “hook or cog complying with Clause 13.1.2.7 or by welding of the fitment to a longitudinal bar or by a welded splice, or by lapped splices.”

A hook consists of either a 180° or 135° bend plus a straight extension which is the longer of $4d_b$ or 70 mm. The internal diameter of the bend must comply with Clause 17.2.3.3 of AS 3600 (2018), which for D500N bars is a minimum of $4d_b$ and 500L and R250N bars is $3d_b$. Smaller diameter bends are allowed for fitments as they are elements that will not be rebent and according to Clause 8.3.2.4(a) “*enclose a longitudinal bar with a diameter not less than the diameter of the fitment bar*”, in the corner of the fitment. A cog consists of a 90° bend with an internal diameter no smaller than that for a hook, and no greater than $8d_b$. The total length is also the same as that for a hook. The requirement for a maximum $8d_b$ bend diameter, is that in terms of development length, a $10d_b$ bend diameter is taken as a straight bar according to Clause 13.1.2.5 of AS 3600, and therefore will not be as effective at anchoring the end of a fitment having the required minimum straight extension.

Welding is mentioned in Clause 13.2.6 of AS 3600, with little guidance provided other than to say that the welded connection “*shall not fail prematurely in tension or compression before the reinforcing bars, unless it can be shown that the strength and ductility of the concrete member meets the design requirements.*” The requirements for welding are given in AS/NZS 1554.3³, however, the loadbearing weld between a fitment and a longitudinal bar is not covered, so designers are on their own regarding specifying requirements. Providing sufficient weld between a fitment and longitudinal bar to provide anchorage may also not be possible. For welded splices, these are covered by Clause 3.2.2 of AS/NZS 1554.3 with minimum weld lengths provided in Table 3.2 for both single and double-sided lap splices. As a general rule, the SRIA would recommend that any welding of reinforcement should be carried out in factory-controlled conditions by suitably trained and qualified welders. This being the case, it is more economical to have single unit fitments bent and supplied. Welding fitments on site as a means to correct omissions is not only expensive, but achieving a good quality site weld in less than ideal conditions and probably with limited access is doubtful.

The required lap length of splices in tension is covered in Clause 13.2.2 of AS 3600. However, for fitments adjacent to the cover concrete, Clause 8.3.2.4 of AS 3600 requires the length to be increased by a factor of 1.3. Similar to site welding, the SRIA considers this to be poor detailing practice, because should the cover concrete be lost or subject to cracking, the effectiveness of the lap will be lost or severely compromised. This may occur under earthquake actions, and is why for limited and moderately ductile shear walls, Clause 14.6.7 of AS 3600 requires the ends of all horizontal lapped bars to be provided with 135° hooks, to ensure the ends are anchored in the confined core of the element, in case the unrestrained cover concrete is lost.

Note that the anchorage option of a lapped splice introduced in Clause 8.3.2.4 of the 2018 revision of AS 3600, is based on Clause 8.3.2.4 of the bridge design Standard AS 5100.5 (2017)⁴, where lapped splices are included to allow for the deep infrastructure beam sections and the requirement to allow access to place and fix bottom reinforcement and tendons. However, Clause 8.3.2.4 of AS 5100.5 requires that where lapped splices are used, fitments adjacent to the cover concrete must be provided with a hook at the end of each lapped bar, similar to the requirement for limited and moderately ductile shear walls above.

To provide additional guidance to designers over the anchorage of fitments, Clause C8.3.2.4 of the AS 3600 Commentary⁵ includes wording advising of the anchorage effectiveness of various types of fitments **Figure 2**.

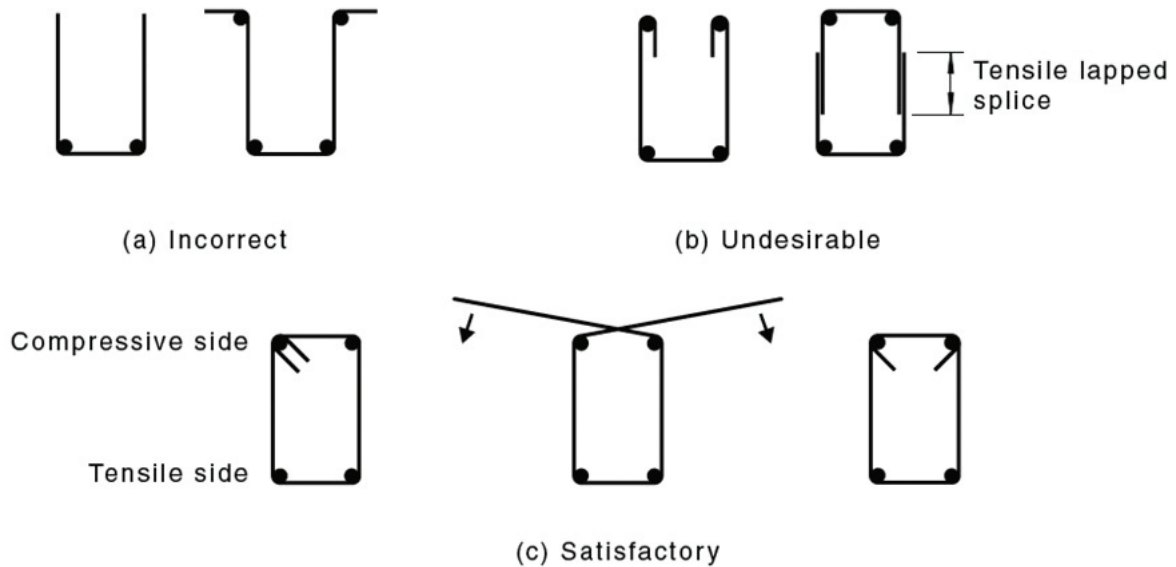

Figure 2 Suitability of fitment anchorages (Figure C8.3.2.4(B) of AS 3600 Commentary⁵)

The open fitments shown in **Figure 2(a)**, according to the Commentary, “do not provide confinement for the concrete in the compression zone and is undesirable in heavily reinforced beams where confinement of the compressive concrete may be required to improve ductility of the member.” They are therefore considered as incorrect. The use of a 90° cog is also discouraged, with the Commentary advising that “fitment hooks should be bent through an angle of at least 135°,” to stop the anchorage becoming ineffective if the cover is lost.

Regarding the anchorage types shown in **Figure 2(b)**, these are described as undesirable. While hooks provide anchorage of the fitment at the top, hooks do not form a closed fitment, and the open top provides no confinement to the compression zone, and hence no improvement of ductility. The beam detail shown in **Figure 3** is typical of detailing that the SRIA sees in many heavily reinforced transfer beams to allow placement of the bottom reinforcement and post-tensioning tendons. The undesirable open fitments shown, anchored by a 180° hook at the top, are also commonly used in post-tensioned band beams to allow the placement of tendons **Figure 4**.

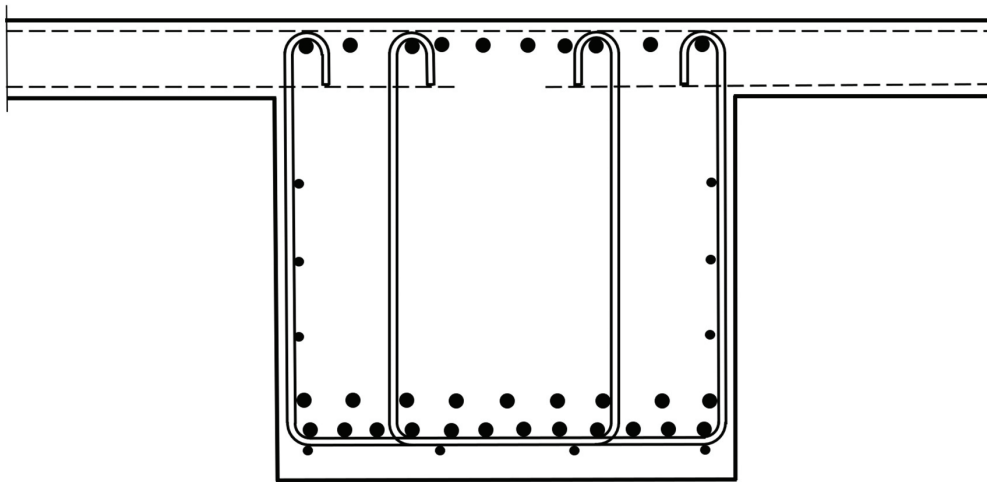

Figure 3 Reinforcement detailing to transfer beam



Figure 4 Undesirable open fitments used to allow placement of post-tensioning tendons

Note that if beams are subjected to torsion, then Clause 8.3.3(a) of AS 3600 requires torsional reinforcement to have closed fitments. Also, Clause 8.3.1.6 of AS 3600 states that “*Compressive reinforcement required for strength in beams shall be adequately restrained by fitments in accordance with Clause 10.7.4.*” This is the clause in the column section of AS 3600 for the restraint of longitudinal reinforcement in columns. In other words, the longitudinal bars in the top of the beam need to be restrained as though it were a column. Clearly the detail shown in **Figure 3** does not comply with this requirement.

The top reinforcement in a slab, as shown in **Figure 5**, should not be taken as providing this restraint, or acting to close the top of the fitment. Closed fitments, as detailed, should still be provided. The American Concrete Institute (ACI 318M-19)⁶ have provisions for installing a cap tie (**Figure 6**) to form a closed fitment where required. Note that the 90° cog is always located on the slab side for perimeter beams where it is less likely to lose anchorage from the cover concrete being lost.

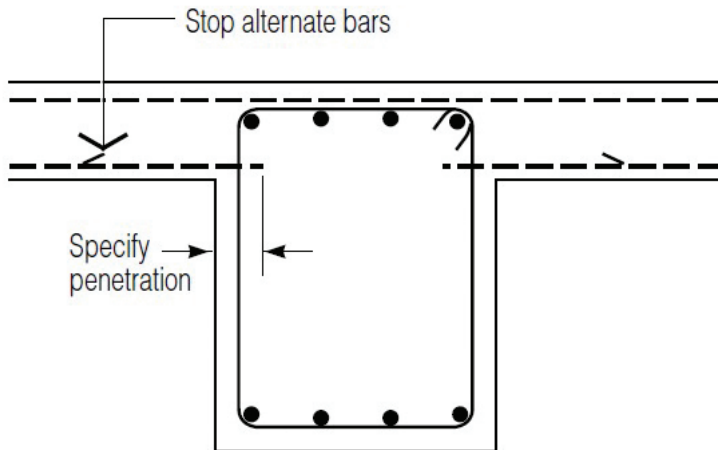

Figure 5 Top reinforcement in slab no substitute for a closed fitment

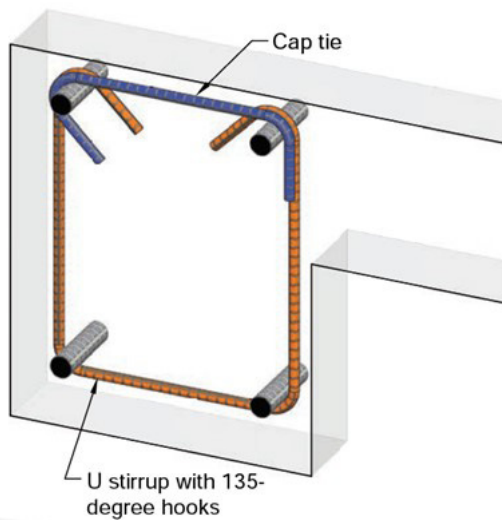

Figure 6 Cap or closing fitment provided to form closed fitment (Figure R9.7.7.1 from ACI 318M-19⁶)

Figure 2(b) also shows fitments with tensile lapped splices as being undesirable. This is also for the reason that if the unrestrained cover concrete is lost, then lapped splices are ineffective. While two 'U' bars lapped in this fashion are allowed in ACI 318M-19⁶, there are limitations on where they can be used. **Figure 7** shows a transfer beam in the Copthorne Hotel in Christchurch where the cover concrete was lost to both the column and transfer beam during the 2011 earthquake. This demonstrates the undesirable nature of lap splicing the fitments vertically down the sides of beams as shown in **Figure 2(b)**.



Figure 7 Cover concrete to column and transfer beam lost due to earthquake action
(*photograph courtesy of Peter McBean*)

The fitments that are shown as being satisfactory in **Figure 2** are all examples of closed fitments. Note that the centre diagram in **Figure 2(c)**, while not having 135° hooks, has the ends of the fitment anchored well into the slab by the development length of the bar. The example shown in **Figure 6** is one acceptable way of achieving a closed fitment using multiple units of reinforcement.

Spacing of Fitments

In the 2018 version of AS 3600, Clause 8.2.1.6 required transverse shear reinforcement where either the design shear force $V^* > \phi(V_{uc} + P_v)$, or the torsional moment $T^* > 0.25\phi T_{cr}$, or the overall depth of the member $D \geq 750$ mm. If transverse shear reinforcement was required, then Clause 8.3.2.2 specified the maximum spacing by requiring that: *“In members not greater than 1.2 metres in depth, the maximum longitudinal spacing shall not exceed the lesser of 300 mm and 0.5D; otherwise, the longitudinal spacing shall not exceed 600 mm.”* So, for members greater than or equal to 1.2 m in depth, the maximum spacing was 600 mm.

Amendment 2 to AS 3600 (2018) published in 2021, replaced $V^* > \phi(V_{uc} + P_v)$ with $V^* - \gamma_p P_v > k_s \phi V_{uc}$. The introduction of the ‘step factor’ k_s is to avoid a significant change from where shear reinforcement is and is not required. It varies from 1.0 where $D \leq 300$ mm to 0.5 for $D \geq 650$ mm.

Amendment 2 also changed the spacing requirements where shear reinforcement is required, which now states that: *“Shear reinforcement shall be spaced longitudinally not further apart than 0.5D or 300 mm, whichever is less. Where $V^* \leq \phi V_{u.min}$, the spacing may be increased to 0.75D or 500 mm, whichever is less.”* So, the maximum fitment spacing is now 500 mm regardless of the beam depth.

However, if the design shear force $V^* \leq k_s \phi V_{uc} + \gamma_p P_v$ or the torsional moment $T^* \leq 0.25\phi T_{cr}$, or the beam or one-way slab depth is less than 750 mm, then there is no requirement for shear reinforcement and AS 3600 contains no guidance on the size or spacing of fitments.

When considering the size and spacing that the fitments in these areas should be, there are a few factors to consider. Firstly, the function of fitments is to allow the assembly of reinforcement cages and support of the longitudinal reinforcing bars within a reinforcement cage. Often beam cages will also be used to support the top reinforcement in the slab where it extends over the beams. Also, if beam cages are prefabricated on site to be lifted into position once the formwork has been completed, the fitments need to be robust enough to maintain the shape of the reinforcement cage during handling and placement into the forms.

The minimum size of fitments will depend on the weight of reinforcement to be supported and the spacing of the fitments. Regarding the spacing, a maximum of 500 mm, consistent with Clause 8.3.2.2 of AS 3600, appears reasonable in terms of allowing the longitudinal reinforcement to be fixed securely into a cage. In terms of the size, while specifying the minimum of R10 fitments to reduce the amount of reinforcement is an option, good detailing practice is to keep all fitments for a beam the same size. The SRIA would therefore recommend that all fitments in a beam be kept the same size as that required for shear or torsion, and only their spacing along the length of the beam be adjusted. Good detailing practice is also to minimise the number of different spacings specified along the beam.

Concerning the requirement for minimum shear reinforcement, Commentary Clause R9.6.3.1 of ACI 318M-19 also provides some further guidance for beams subjected to repeated loading:

“For repeated loading of beams, the possibility of inclined diagonal tension cracks forming at stresses appreciably smaller than under static loading should be taken into account in design. In these instances, use of at least the minimum shear reinforcement expressed by 9.6.3.4 is recommended even though tests or calculations based on static loads show that shear reinforcement is not required.” Note that this refers to Clause 9.6.3.4 of ACI 318M-19. Based on this, if beams are subjected to repeated loading that may lead to fatigue, at least the minimum shear reinforcement required by AS 3600 at the maximum spacing required by Clause 8.3.2.2 of AS 3600 should be provided as a precaution, even if the shear force or torsional moment are less than the values specified in Clause 8.2.1.6 of AS 3600.

References

1. Australian Standard AS 3600 Concrete structures, 2018.
2. Australian Standard AS 3600 Concrete structures, 2009.
3. Australian New Zealand Standard AS/NZS 1554.3 Structural steel welding Part 3: Welding of reinforcing steels, 2014.
4. Australian Standard AS 5100.5 Bridge design Part 5: Concrete, 2017.
5. Australian Standard AS 3600:2018 Sup 1:2022, Concrete structures – Commentary (Supplement 1 to AS 3600:2018).
6. American Concrete Institute Standard, ACI 318M-19 Building Code Requirements for Structural Concrete and Commentary on Building Code Requirements for Structural Concrete, 2019.